



in association with



WMC8947 Washing Machine



Kg Load



Steel Seal™



Active Drum™



G-Factor



WiFi for ConnectLife



Prepared connection to external auto dosing units



Prepared connection to external payment systems

Quick Overview

- Load capacity: 9kg; Drum size: 80L
- Maximum spin speed: 1400 rpm
- Finish: Touch Proof™ Stainless steel
- 26 programmes
- Connection: 400V / 3ph / 16A / 50Hz / 7.2kW
- Electrical reconfiguration: No
- Pump and valve drain system machines available
- Prepared for Auto Dosing: Yes
- WiFi for ConnectLife: Yes
- Prepared for payment systems (coin, card and AIRwallet): Yes
- Tested over 30,000 cycles



Construction
Operating position: Front-operated
Capacity: 9kg
Door opening: 31cm
Door opening angle: 180°
Door opening: Left hinge
Material: Stainless steel
Base plate: Waterproof with flood sensor
Drum volume: 80L

Electrics
Connection power: 7,200W
Fuse: 16A
Electrical connection: 400V
Frequency: 50Hz
Length of power cable: 2.1m
Phases: 3

Connection of water/drain
Cold and hot water connection: Size 3/4" (adapter 1/2" included)
Inlet hose: PEX inlet hose, able to withstand 10 bar at 95°C (tested to over 50 years)
Drainage capacity: 20l/min
Drain system: Drain valve or pump available

Dimensions
Dimensions (H x W x D): 850 x 595 x 706mm
Packaging dimensions: 920 x 640 x 776mm
Net weight: 92.5kg
Gross weight: 95.9kg
Adjustable feet: 10mm
Depth with door open: 965mm
Inlet hose, length: 1,500mm
Inlet hose: 1,600mm

WMC8947 Washing Machine

Functions
Detection and automatic correction of imbalance in the drum: Yes
Flood protection: Yes
Delayed start: Yes, up to 100 hours
Possible to connect and control via WIFI: Yes
Overheating protection: For motor and electronics

Performance
Residual humidity: 49%
Heater power: 7,000W
Temperature range: Cold - 90°C

Operations
Display type: TFT display
Language: CN, HR, CZ, DK, NL, EN, EE, FI, FR, DE, IT, JP, LV, LT, NO, PL, RU, SK, SL, ES, SE
Detergent dispenser: Three compartment dispenser

Programmes		
Allergy cotton 60°C	White/Coloured wash 60°C Professional	Wool and hand wash 40°C
Allergy cotton 90°C	White/Coloured wash 40°C Professional	MOP wash 60°C
Allergy synthetics 60°C	Quick 60°C Professional	MOP wash 90°C
Drum cleaning	Quick 40°C Professional	Microfibre 40°C
Allergy synthetics 40°C	White/colour 20 °C	Microfiber wash 60°C
Eco 40-60 °C	Synthetic wash 40°C Professional	Disinfection 60°C
Rough wash 90°C	Drain	Disinfection 40°C
Rough wash 60°C	Spin	Disinfection 90°C
White wash 90°C Professional	Rinse	

Pump version

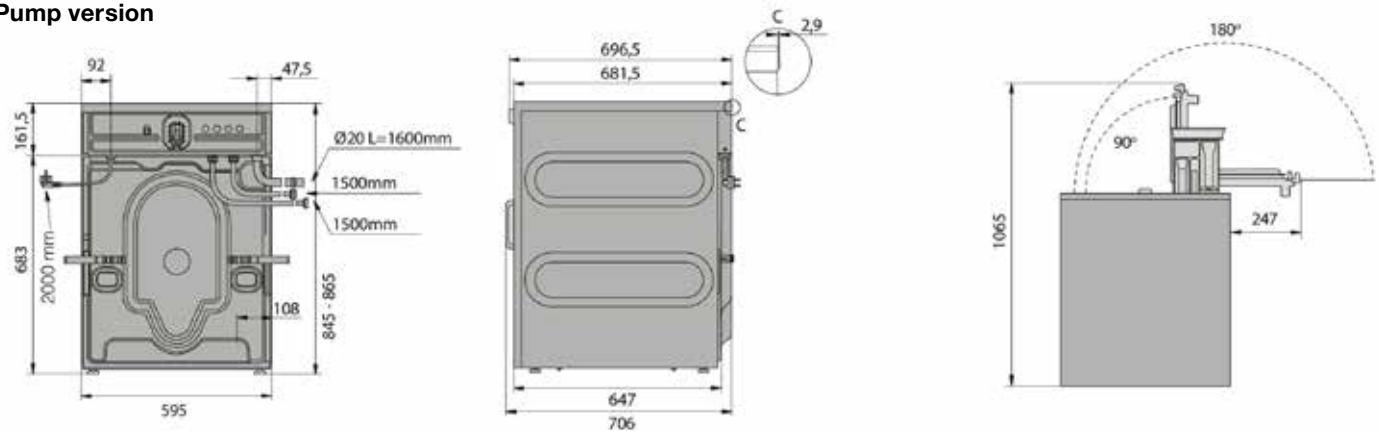

Valve version

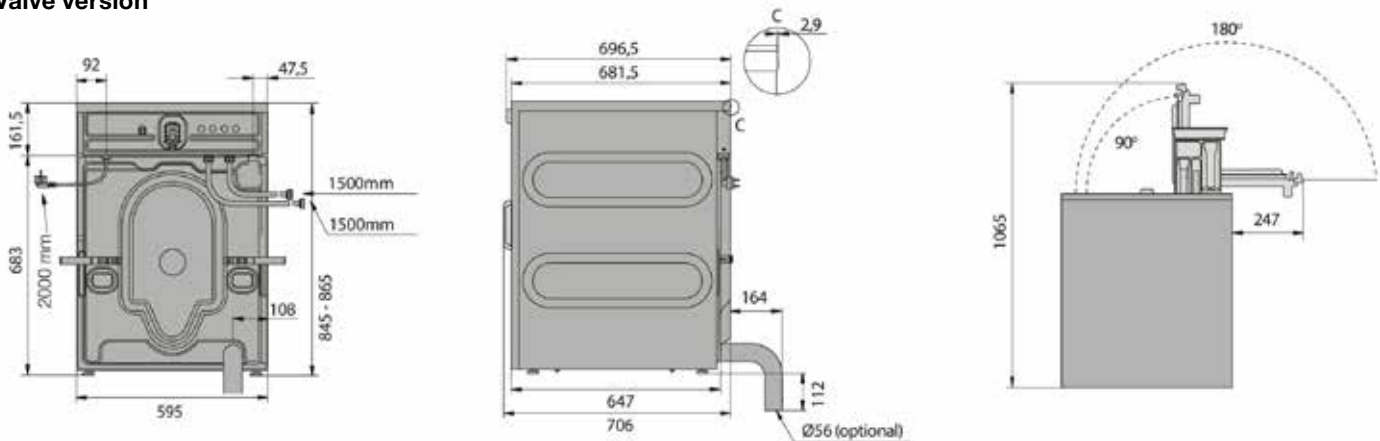

DC Products

Unit 25 Lodge Hill Industrial Park, Westbury Sub Mendip, Somerset, BA5 1EY
 t: 01749 870055 e: sales@dcproducts.co.uk w: www.laundry.dcproducts.co.uk

