

# **AUTOMATIC MODULAR ICE-CUBE MAKER**

## **CLEANING AND SANITIZING MANUAL**

FOR AUTHORIZED MAINTENANCE PERSONNEL ONLY

24769 ed. 04-2007



1

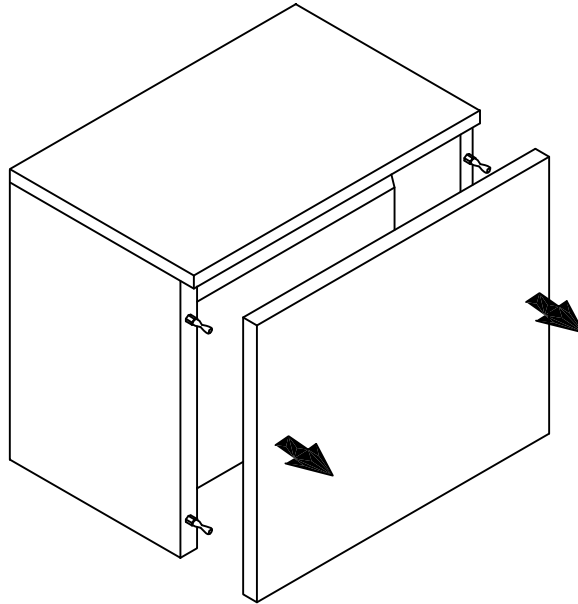



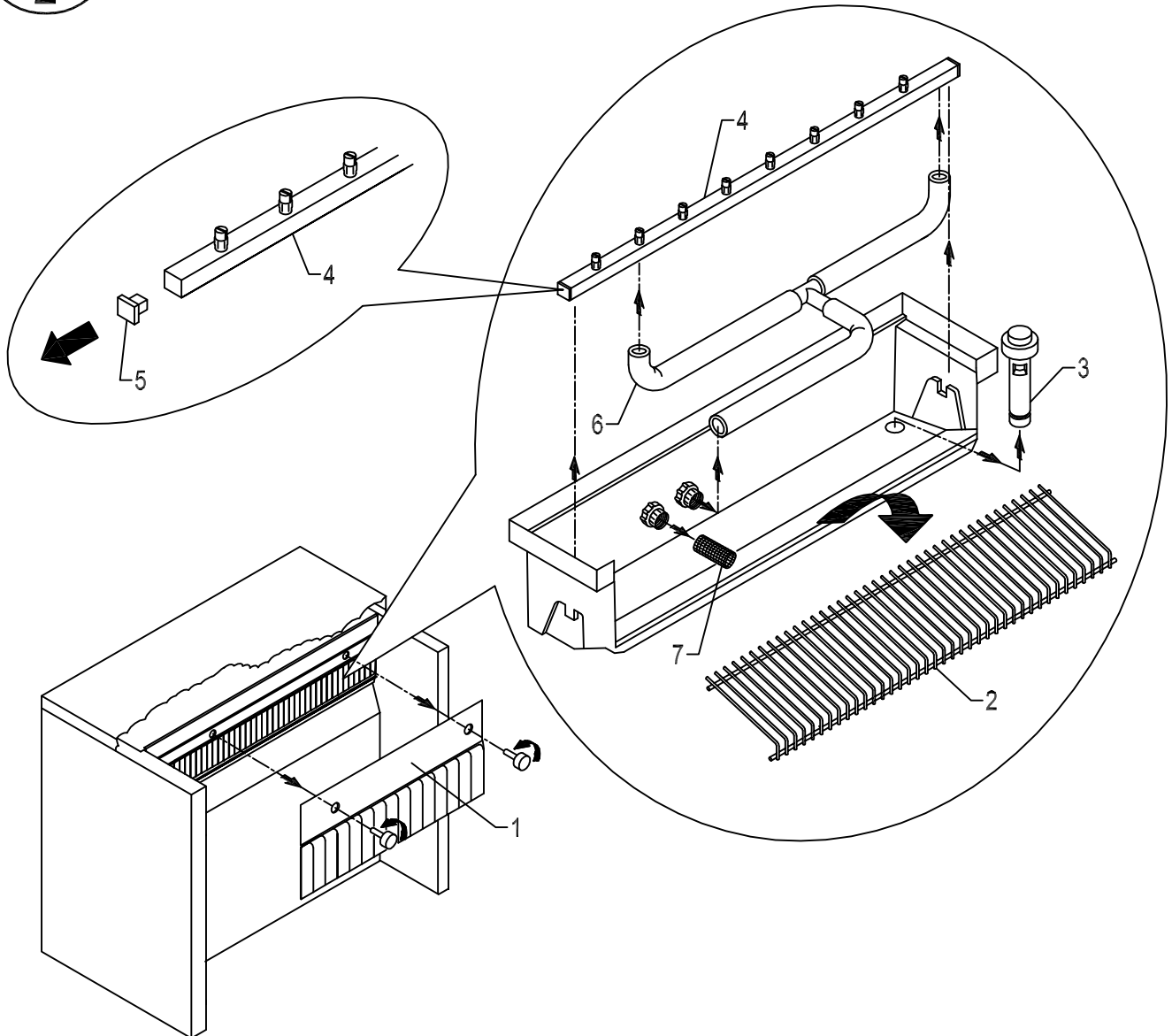

2

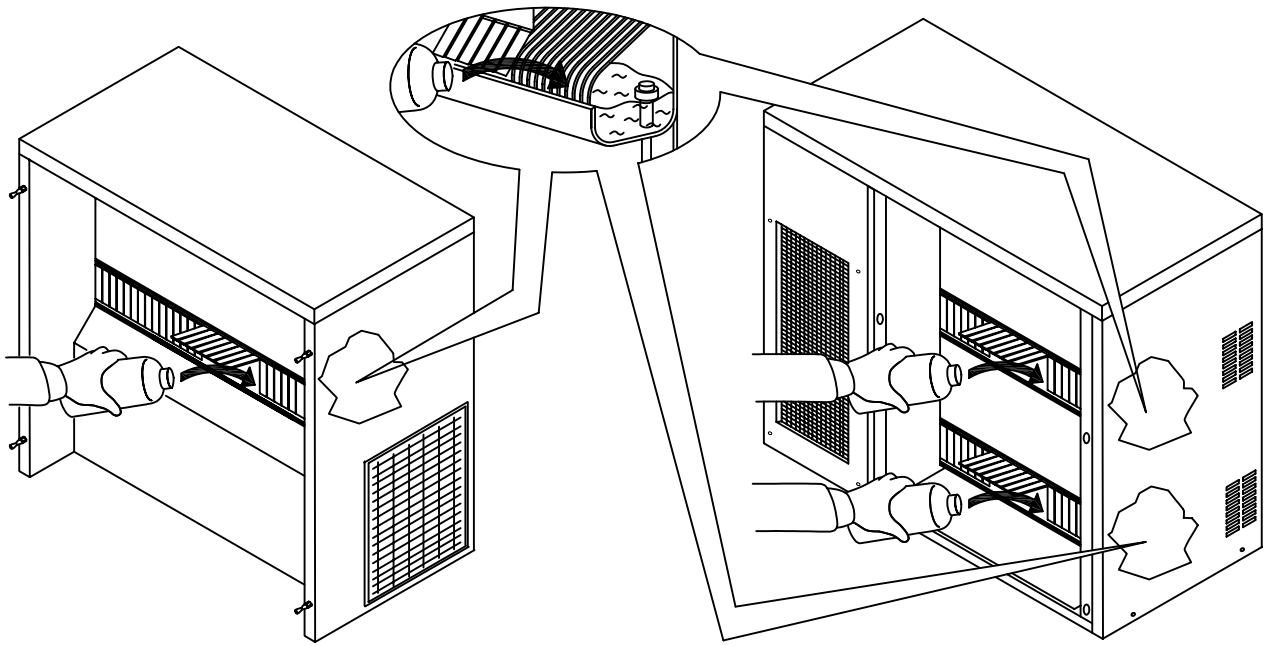

3



 24  	90	150	300
	6	9	2 x 9

4

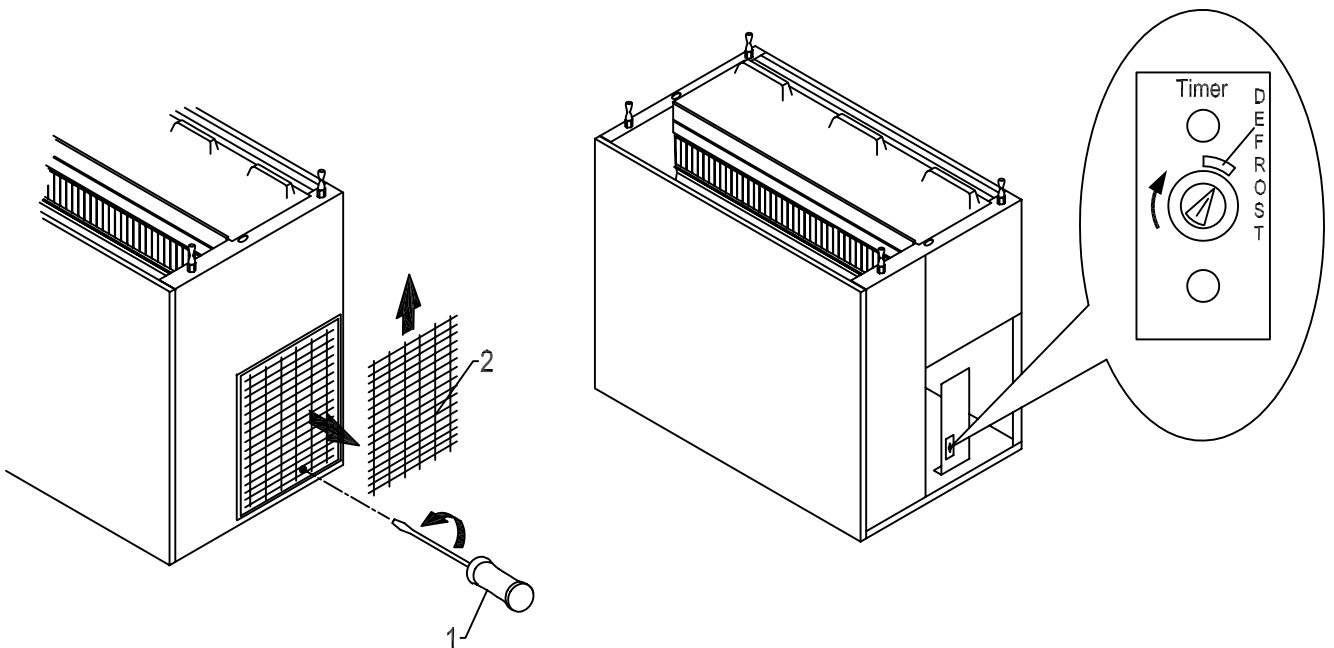

5

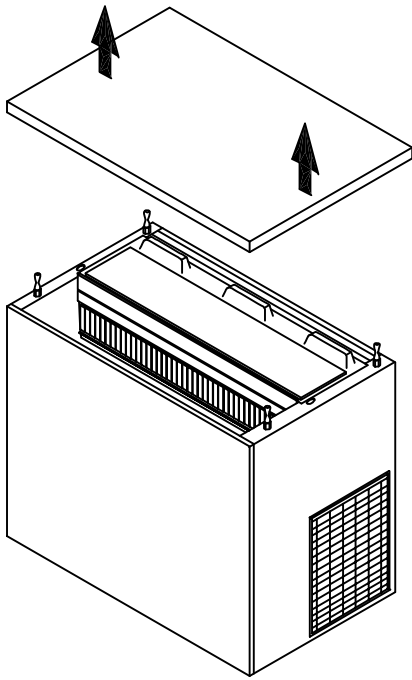

6

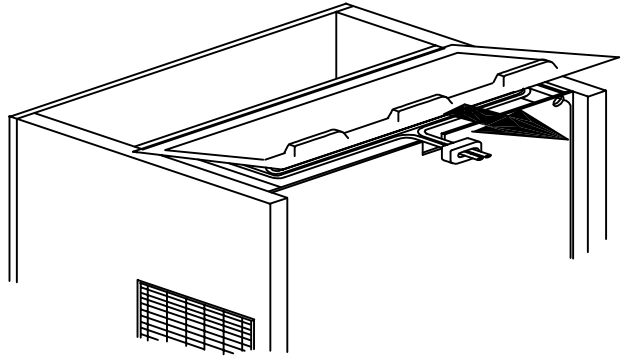

7

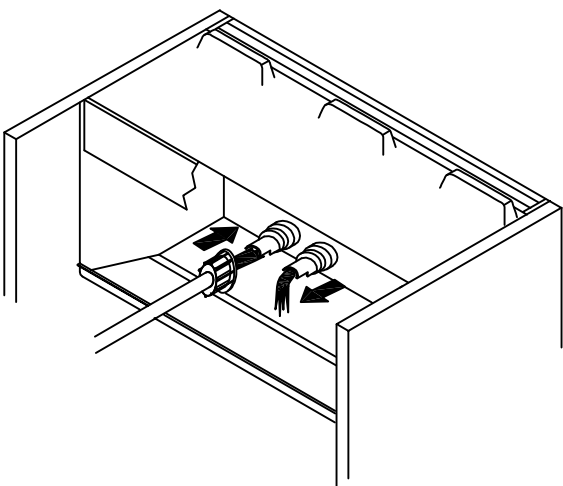

8

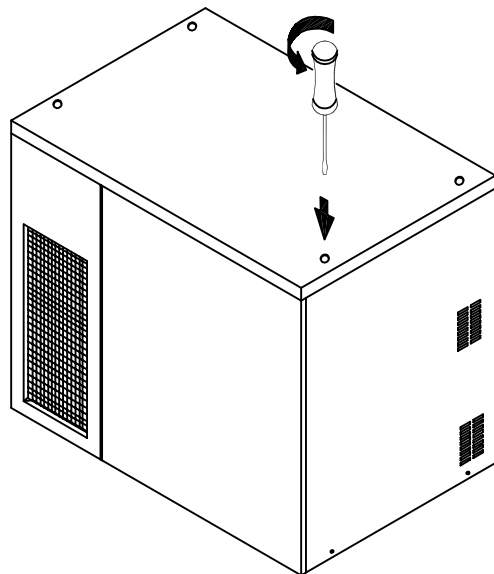

9

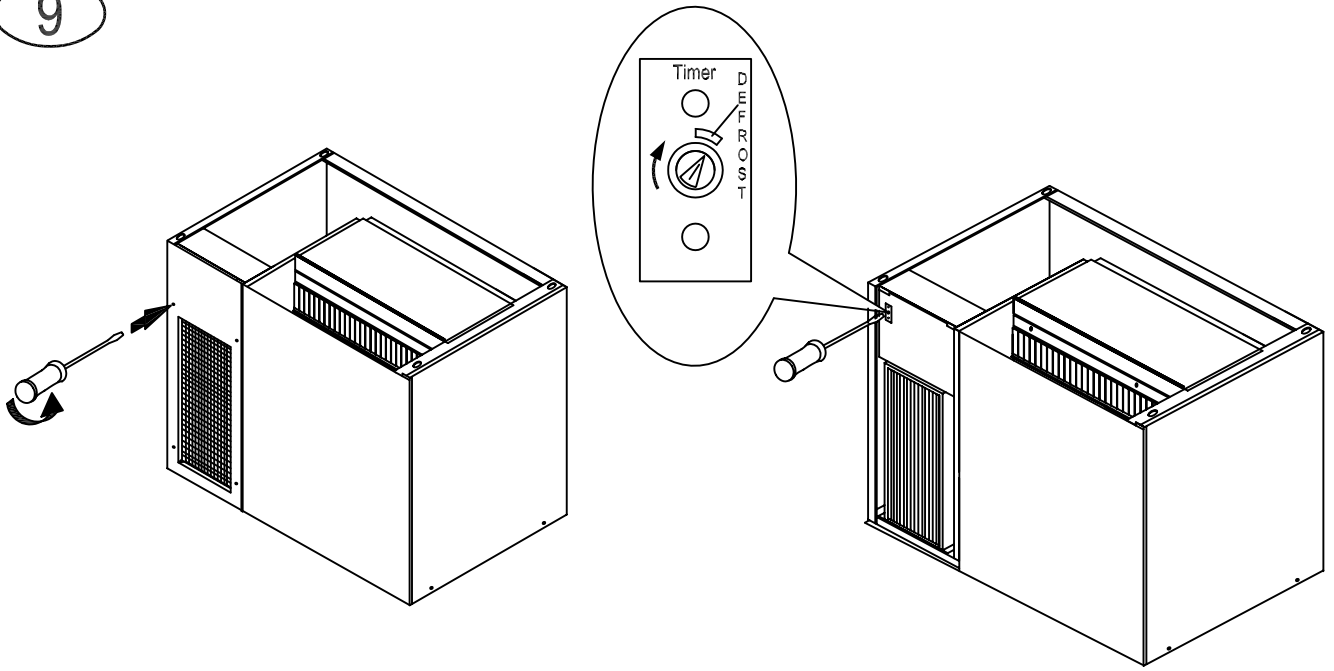

10

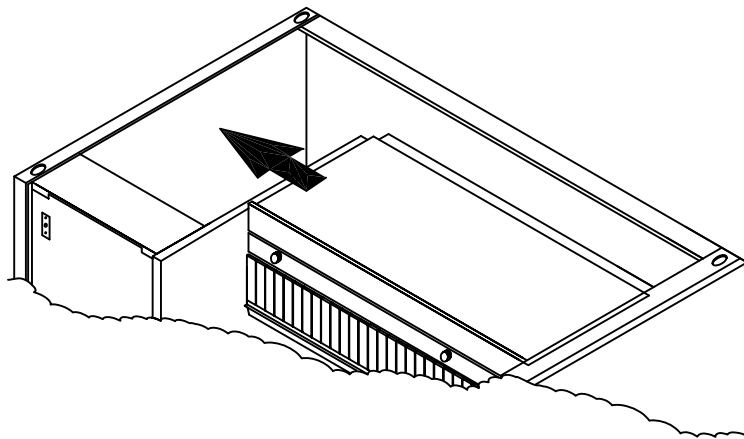

11

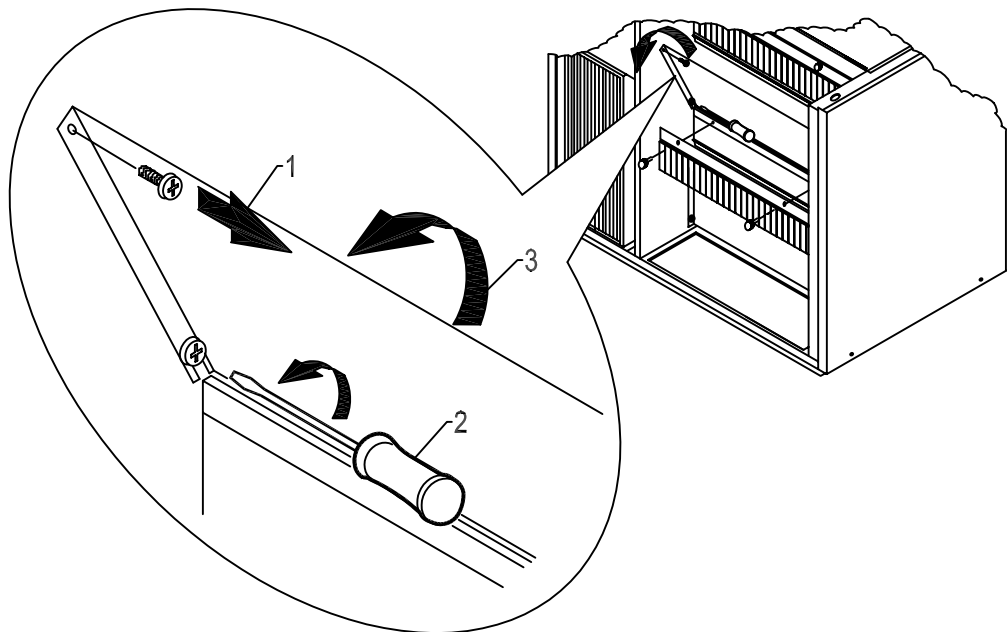

# TABLE OF CONTENTS

- 1 RECOMMENDATIONS
- 2 CLEANING
- 3 SANITIZING
- 4 NOTE FOR MODEL WITH DAILY PRODUCTION OF 300 kg

The figures in this manual are of a general nature. Some details may therefore differ, depending on the specific model.

The Manufacturer declines all liability for any inaccuracies in this cleaning and sanitizing manual due to printing or transcription errors. The Manufacturer also reserves the right to make any modifications to the products that may be necessary or useful, also in the interest of the user, without impairing the products' essential features of functionality and safety.

## 1 RECOMMENDATIONS

This cleaning and sanitizing manual forms an integral part of the automatic modular ice-cube maker (also more simply called “appliance” in the text) and must be kept for possible future consultation. In the event of the appliance being sold or transferred to another person, this manual must be handed over to the new user, in order to enable him to become familiar with the operation of the equipment and the corresponding advice and recommendations.

This cleaning and sanitizing manual does not replace the instruction book supplied with the ice maker, which should be referred to for all subjects not covered by this manual; in particular, please refer to the instruction book for the start-up procedure, connection of the appliance to the electricity mains and water supply, and cleaning of components not expressly mentioned in the cleaning and sanitizing manual.

The frequency of cleaning and sanitizing operations can vary, depending on:

- temperature and environmental conditions
- temperature and quality of water (hardness, presence of grit, etc.)
- quantity of ice produced, or time of use of ice-cube maker
- periods of non-use of ice-cube maker

TO ENSURE CORRECT CLEANING AND SANITIZING OF THE ICE-CUBE MAKER, PERFORM THE OPERATIONS DESCRIBED IN THIS MANUAL AT LEAST ONCE A MONTH.

### !! IMPORTANT:

- the operations described in this manual must only be performed by skilled, authorized personnel
- the appliance must be installed in a hygienically clean location; avoid premises such as cellars and storerooms, because poor hygiene promotes the formation and proliferation of bacteria in the ice-cube maker
- a cleaning and sanitizing kit specifically designed for this appliance is available from your dealer
- do not use corrosive substances to remove limestone from the appliance, because this will invalidate the guarantee, and may cause serious damage to the materials and components of the appliance
- gloves suitable to protect against cuts must be worn when performing all operations involving handling of sheet metal parts in particular
- gloves suitable to protect the skin against the substances used must be worn when performing all cleaning and sanitizing operations
- wear suitable goggles during cleaning and sanitizing operations to protect the eyes against splashes of the substances used
- take care not to spill water or solutions on the wiring or the power cable

## 2 CLEANING

1. wait for ice cubes to drop, switch off appliance, **disconnect from the electricity mains supply** and remove front panel (Fig. 1)
2. remove flag support assembly (1 in Fig. 2) and ice-cube slide (2 in Fig 2) and extract overflow pipe (3 in Fig 2) to drain water present in basin
3. reposition overflow pipe and fill basin with a 25% solution of water and white vinegar. Refer to the table for the amount of solution required, depending on daily output (Fig. 3)
4. refit front panel and operate appliance for five one-minute periods, with a five-minute interval between each

### !! IMPORTANT:

**The pump must be in operation during cleaning cycles (check that water is sprayed). If it is not, immediately adjust the timer regulation screw by turning it clockwise until the indicator on the pin exits from the zone marked DEFROST.**

To reach timer, remove grille on right-hand side of appliance with a Phillips screwdriver, and regulate timer with a flat-head screwdriver (Fig. 4).

5. switch off and **disconnect machine from electricity mains** and water supply
6. remove top by raising it from chassis of appliance (Fig. 5)

7. remove evaporator cover panel (Fig. 6) and clean top part of evaporator and evaporator cover panel with water and vinegar solution
8. remove any sediment from evaporator and evaporator cover panel using a brush with soft bristles and a non-abrasive sponge
9. pour plenty of cold water onto the evaporator and with the aid of the brush, direct the sediment removed into the basin beneath, taking care not to obstruct the holes in the base of the evaporator. During cleaning of evaporator, take care:
  - not to bend coils
  - not to detach water supply pipes
  - not to remove evaporator thermostat
10. remove (Fig. 2) and clean with ordinary washing-up liquid:
  - flag support assembly (1)
  - ice-cube slide (2)
  - overflow pipe (3)
  - sprayer bank (4), taking care to remove side caps (5)
  - sprayer bank feed pipe (6)
  - pump filter (7)
11. clean with the same washing-up liquid:
  - evaporator cover panel
  - inner basin
12. rinse and refit (Fig. 2):
  - pump filter (7)
  - sprayer bank feed pipe (6)
  - sprayer bank (4), after repositioning side caps (5)
  - overflow pipe (3)
  - evaporator cover panel (Fig. 6)
13. prepare to perform the sanitizing operations described in the next chapter

### 3 SANITIZING

Use a 200 mg/l solution of sodium hypochlorite and water (or a solution of ½ ounce of normal bleach to 1 gallon of water) or one of the solutions commonly used to disinfect babies' feeding bottles; in this case, check that the sanitizing product is:

- authorized by your Country's Ministry of Health
- suitable for use with food machines
- not harmful to the materials and components of this appliance

For the directions for use and concentrations, please refer to those shown on the packaging and recommended by the manufacturer. We recommend using the solution at the temperature of 25°C.

1. fill basin with sanitizing solution. Refer to the table for the amount of solution required, depending on daily production (Fig. 3)
2. refit ice-cube slide (2 in Fig. 2) and flag support assembly (1 in Fig. 2)
3. refit front panel

**!! Before connecting the appliance to the mains electricity supply, ensure that all cables and electrical wiring are perfectly dry.**

4. operate ice maker for five one-minute periods, with a five-minute break between them

**!! IMPORTANT:**

**The pump must be in operation during sanitizing cycles (check that water is sprayed). If it is not, immediately adjust timer regulation screw by turning it clockwise until the indicator on the pin exits from the zone marked DEFROST.**

To reach timer, remove grille on right-hand side of appliance with a Phillips screwdriver, and regulate timer with a flat-head screwdriver (Fig. 4).

5. switch off and **disconnect machine from the mains electricity** and water supply
6. remove front panel (Fig. 1)



7. pour sanitizing solution onto top part of evaporator, distribute with a brush, and rinse thoroughly with cold water
8. remove (Fig. 2) and immerse in sanitizing solution for 30 minutes:
  - flag support assembly (1)
  - ice-cube slide (2)
  - overflow pipe (3)
  - sprayer bank (4) and side caps (5), after removing them from the bank
  - sprayer bank feed pipe (6)
  - pump filter (7)
  - evaporator cover panel (Fig. 6)
9. drain sanitizing solution remaining in pump body by introducing pressurized water into the suction pipe and checking that the water exits from the delivery pipe (Fig. 7)
10. thoroughly rinse inner basin with cold water
11. thoroughly rinse ice-cube slide, evaporator cover panel, sprayer bank and the corresponding side caps, flag support assembly, overflow pipe, pump filter and sprayer bank feed pipe under running water
12. refit parts previously removed
13. refit front panel of appliance
14. reposition top, securing it to rear panel with the screw, if present

The ice-cube maker can now be reactivated as specified in the instruction manual.

**!! IMPORTANT:**

**All the ice produced during the first five cycles after cleaning and sanitizing operations must be discarded.**

**When the appliance is cleaned and sanitized, its bin must also be cleaned and sanitized.**

**THE FOLLOWING ADDITIONAL OPERATIONS ARE REQUIRED FOR SOME SPECIAL MODELS:**

**4 NOTE FOR MODEL WITH DAILY PRODUCTION OF 300 kg**

To access timer, remove front left-hand panel of appliance by unscrewing fixing bolts (Fig. 9). Regulate timer as described in chapters 2 and 3.

To access top evaporator:

- remove top of appliance by unscrewing fixing bolts (Fig. 8)
- remove top evaporator cover panel by sliding it to the left (Fig. 10)

To access bottom evaporator (Fig. 11):

- remove front right-hand panel of appliance by unscrewing fixing bolts
- remove the two top bolts (1) securing the partition (one on each side), and loosen the bottom bolts (2)
- rotate partition outwards (3)
- remove evaporator cover panel

Repeat the cleaning and sanitizing operations described in chapters 2 and 3 on both evaporators.